

EXPERTIP

Category	DRYING
Keywords	Dryer fabric, dryer fabric installation, dryer fabric start-up, installation safety, fabric tensioning, seam assist, dryer fabric seaming

Tips for Installing and Starting Up your Dryer Fabrics

The first step in getting maximum performance from your dryer fabrics is to make sure you handle and install them correctly. Having an action plan and executing it properly not only minimizes machine downtime, but also ensures that the fabrics will run trouble-free on your machine.

As part of your action plan, consider the following questions:

- 1. Do we need to do any maintenance or repair work to the drying section to correct for misalignment or potential damage to the fabric?** (If the fabric you are currently running is hard to guide or showing signs of misalignment, you should diagnose the cause(s) of the problem and correct before the new fabric is put on).
- 2. How should we prepare the new fabric and position it for installation?** (Care should be taken in transporting the fabric from storage to the machine floor. Clean the area before placing the new fabric on it. The labels on the packaging show the machine side, sheet side, and direction of roll-up, so you can position the box correctly before opening).

Safety First!

First priority, of course, is SAFETY. The following precautions should be taken when installing a new fabric:

1. Assign a LO-TO-TO = Lock-Out, Tag-Out, Try-Out safety coordinator.
2. Wear appropriate personal safety equipment, including gloves.
3. Use the right equipment and tools (e.g. use a bandcutter instead of screwdriver or pliers).
4. Be vigilant about moving machinery, pinch points, etc.
5. Communicate, coordinate, and observe.
6. Never place body parts under/between cantilevered equipment.
7. Report anything UNSAFE.
8. Use extreme caution when cutting plastic bands off the fabric tube. Stand to the side of the band when you cut it.

Dryer Fabric Installation

Each machine is different and may have different Standard Operating Procedures (SOP) for fabric installation. But, there are some points that should always be considered when installing a dryer fabric:

1. Make sure all crew members understand the installation procedure and position team members appropriately before starting.
2. Before installation begins, make sure to unload all doctor blades as well as blow box and PV box seals and flaps.
3. Clean the dryer section components thoroughly to eliminate debris.
4. Identify the machine side and sheet side of the new fabric, as well as the running direction. You may place the new fabric into saddles so that it turns freely during installation. This helps minimize misalignment as the fabric is pulled onto the machine.
5. If you install your new fabric directly from the shipping box, proper placement of the box is critical. It must be level, perpendicular to the machine center line, and have adequate clearance from the machinery. It is common to use a plumb bob (Figure 1) to find the proper placement of the box.

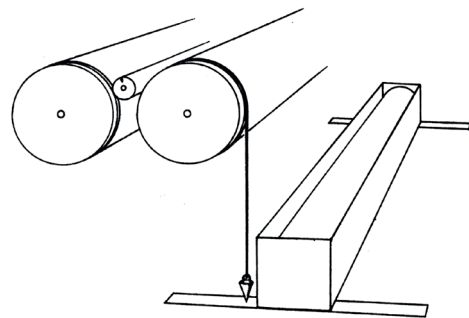

FIGURE 1. Use of plumb bob for proper placement of box.

6. If the box cannot be placed in the right position, the usual procedure is to pull the fabric completely on the machine without moving the box and join the seam even if the fabric is not in the right position and alignment. If you do this, turn the guide palm to the side and tie it off (Figure 2) so that the guide roll is centered and the fabric will go on straight. When seaming is complete, turn the guide palm back to its normal position and untie if before the machine is started up.

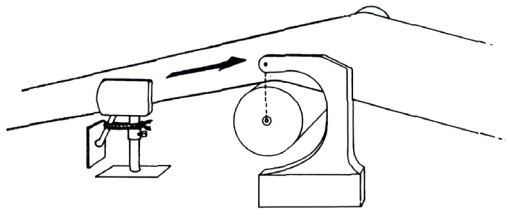

FIGURE 2. Centering guide roll during installation.

7. Typically, the old fabric is used to pull your new fabric into position. Cut the old fabric just behind the seam area and punch a series of holes. Use a series of short ropes for the tie-in (Figure 3). If your old fabric is bowed, the lengths of the ropes must be adjusted so that your new fabric will be pulled onto the machine straight and true.

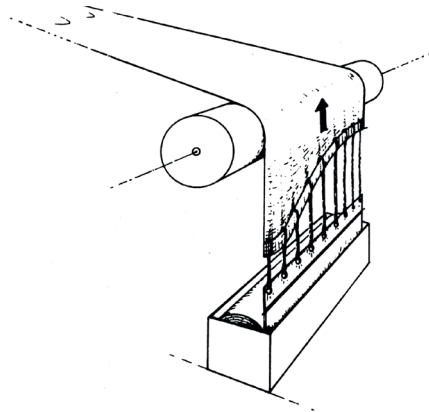

FIGURE 3. Tying new fabric to the old fabric.

8. If you are using a ring bridle arrangement (Figure 4) run off the old fabric into the basement so that it threads the rope attached to the new fabric through the dryer section. For this to work properly, each of the ropes attached to the fabric and ring must carry an equal portion of the load. If your old fabric is no longer present, thread the rope by hand. In either case, it is essential to run the rope straight along the center line of the machine.

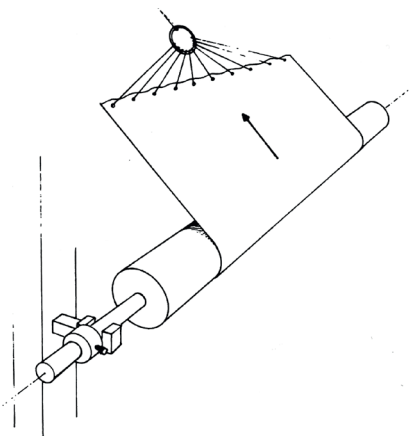

FIGURE 4. Ring bridle arrangement.

9. Some of the potential problems aligning your new fabric with a ring bridle can be eliminated by using a lead-on harness (Figure 5). This is a triangular-shaped leader which connects to the new fabric via a fringed area across its width to which ropes can be tied.

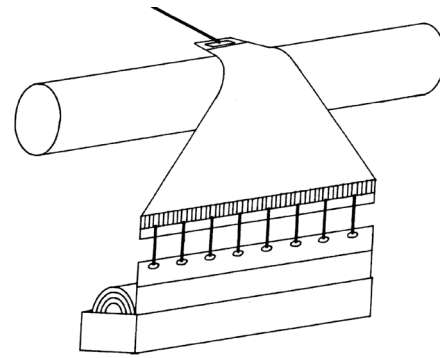

FIGURE 5. Lead-on harness arrangement.

Dryer Fabric Seaming

1. Joining the ends of the fabric and installing the wire in the seam should be done on as flat a surface as possible. This might be a catwalk or a portable platform, which can be inserted in the machine frame at the point where the seam is to be joined. If a flat surface is not practical, a dryer drum surface is the next most preferred location. A felt roll is not desirable due to the amount of curvature, which makes seaming difficult.
2. When the dryer fabric package is opened, locate the joining wire kit and remove before pulling on fabric.
3. The use of a seam assist is strongly recommended. AstenJohnson offers three types of seam assist:
 - A Velcro® Assist, installed at the factory, which holds the ends of the fabric together in order to release the tension caused by the fabrics' weight during the seaming process.
 - A Velcro® Kit, included in the dryer fabric packaging, with self-adhesive strips that can be installed on the fabric at the mill.
 - A Zipper Assist, where the two ends are joined without effort and zipped across the entire width. This removes the fabric strain and can eliminate the requirement for several people to hold the seam together across its width as the pintle wire is inserted.
4. The seaming process should always start from the guiding side, lining up the loops on the guide paddle edge first. Make sure that the alignment marks line up as well.
5. Use a round object or fingers to mesh the seam loops together.
6. Insert the yellow tip of the metal wire into the meshed loops. This will require two people: one to feed the wire into the seam, and one to ensure that that the loops are properly meshed and that no loops are missed by the wire.
7. Be sure not to bend or kink the wire – this will make seaming more difficult.
8. Sometimes the wire becomes difficult to push after it is inserted some distance into the seam. This can be overcome by "sewing" -- pointing the yellow tip out of the seam when progress becomes difficult, pulling the full length of the wire through the seamed part of the fabric to create a large loop, and reinserting the yellow end into the seam. Continue seaming until completed or until another sewing operation is required.

9. Continue seaming until the metal wire exits the other side of the fabric. STOP. Inspect the entire seam to make sure the edges are flush and there are no mismatched loops. Any mismatched or "left over" loops at the back edge is an indication that there is a problem which can cause wrinkles in the fabric and/or operational problems on the machine. This must be corrected before starting up the machine.
10. When everything is ok, pull the metal wire through the seam until about 4-6 in (10-16 cm) of the plastic wire is revealed. Cut off the metal wire where it attaches to the plastic wire, make a loop with the plastic wire, and tuck it back into the seam. Do this on the front and back sides of the fabric. Some mills tie knots in the ends of the wire. This is NOT recommended. Tying off the seam can put the seam under cross-wise tension and cause it to bind.
11. Use pliers to push plastic wire loop all the way into the seam, flush with the front edge where the fabric contacts the guide palm. When tension is applied to the fabric, the joining wire will be held in place securely. As an added precaution, apply silicone to the first inch or so (30 mm) of the seam in the CD, matching the edge doping treatment on front and back sides.

Dryer Fabric Start-up

Here are some points that should be considered when starting up a dryer fabric:

1. Do a final check to ensure that the fabric is square on the machine.
2. Make sure that all team members are clear of the machine before jogging the fabric.
3. Apply just enough movement to the take-up roll to eliminate slack areas in the new fabric.
4. Reset the guide palm and slowly run the fabric (crawl speed) with minimum tension until it has time to set and completely align itself. This procedure is especially critical when installing a dryer fabric on hot dryers; the entire fabric needs to be at the same temperature (crawling for a period of time at the lowest possible tension) before increasing to operating tension. Otherwise, wavy edges may be locked/set in place.
5. Increase tension slowly until operating levels are achieved.
6. Keep a sharp eye on guiding and tension. Adjust as necessary.
7. Check fabric tension frequently for the first 24-48 hours and adjust the stretch as necessary.

Questions?

We are here to help. We distribute **ExpertTips** to help you improve the performance of your paper machine. Not just fabric performance, but the overall efficiency, reliability, and productivity of your mill.

If you have questions about anything you see here, please contact us by emailing expertip@astenjohnson.com or visiting our website www.astenjohnson.com/expertips.

And, if you have suggestions about other topics you would like to receive an ExpertTip on, we would love to hear from you!